

COMMERCIAL VEHICLE INSPECTION SPECIALIST WRITTEN TEST STUDY GUIDE

A Commercial Vehicle Inspection Specialist (CVIS) works at commercial vehicle inspection facilities and enforcement facilities performing routine inspections of commercial type vehicles and drivers to determine if they comply with weight, size, registration, safety, equipment and driver requirements. A CVIS inspects and tests all types of commercial vehicle brake systems for compliance with California Vehicle Codes and other applicable laws and regulations, and when required, refers violators to an enforcement officer for action.

The purpose of this study guide is to help you prepare for the CVIS written test. The written test is divided into three subtests. Each subtest measures knowledge and abilities that are required for success as a CVIS. This study guide has examples of the types of questions that will appear on the test; the correct answer is indicated with an arrow. Please note that the examples are simplified versions of the actual test and are shown for illustrative purposes only. It also provides a list of job-related terminology with which you should be familiar. In addition to reviewing material in this study guide, you may find it helpful to read the relevant parts of the Department of Motor Vehicles', California Commercial Driver Handbook.

SUBTEST 1: INSPECTING COMMERCIAL VEHICLES

Knowledge of methods, materials, tools and equipment used in the construction, overhaul, and testing of commercial braking systems; ability to test and inspect electric hydraulic, and air brake systems.

Subtest 1 measures the basic knowledge and abilities a CVIS must possess to perform routine inspections of commercial vehicles.

Examples

1. The pitman arm connects the
 - (A) sector shaft to the idler arm.
 - (B) steering gear box to drag link.
 - (C) pitman arm to the steering column.
 - (D) steering wheel to the steering wheel shaft.

2. On a commercial vehicle, the kingpin or steering axis inclination is
 - (A) inclination of the wheel plane to the vertical.
 - (B) outward tilt of the bottom of the kingpin.
 - (C) inward movement of the wheel when the kingpin is on an incline.
 - (D) central plane of the steering tire, perpendicular to the kingpin rotation.

3. The brake component pictured below is part of a
- (A) disc brake.
 - (B) wedge brake.
 - (C) electric brake.
 - (D) s-cam air brake.

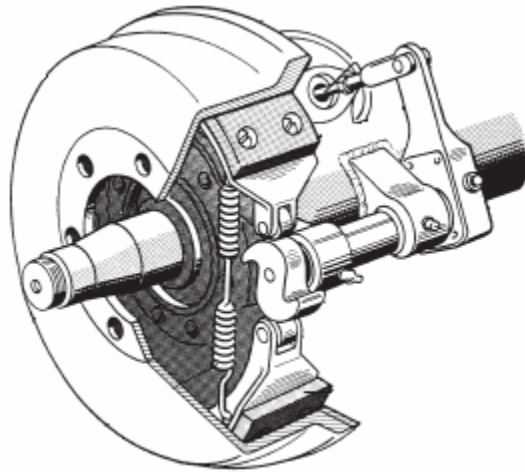

4. A typical split hydraulic brake system with hydraulic leakage or complete failure in one portion of the system
- (A) can cause the entire brake system to fail.
 - (B) can not affect the other portion of the system.
 - (C) may increase the pressure in the brake system.
 - (D) will cause both hydraulic brake reservoirs to lose fluid.

CONTINUED ON PAGE 3

SUBTEST 2: ABILITY TO PREPARE ACCURATE REPORT FORMS

Ability to prepare accurate and legible forms.

Subtest 2 measures the abilities a CVIS must possess to inspect and analyze driver records for accuracy and relate material read to what is seen upon inspection of a commercial vehicle.

Use the information in the Abbreviation Chart below to answer example question #5

ABBREVIATIONS					
ADJ	Adjustment	HM	Hazardous Materials	RQ	Reportable Quantity
APP	Applied	HW	Hazardous Waste	SMKR	Side Marker Light
AUD	Audible	HYD	Hydraulic	STK	Stake
BRK	Brake	ICC	Interstate Commerce Commission	STPLT	Stop Light
BRKLT	Brake Light	INOP	Inoperative	STR	Steering
BTWN	Between	LIC	License	SYS	System
CCR	Calif. Code of Regulations	L /	Left	TRK	Truck
CDL	Com'l. Driver License	MIN	Minimum	TLR	Trailer
CFR	Code of Federal Regulations	MAX	Maximum	TL	Tail Light
DDL	Driver License	NIP	Not In Possession	TRNSIG	Turn Signal
DIS	Disposition	NO	Number	TPV	Tractor Protection Valve
DL	Driver License	O / S	Out of Service	VC	California Vehicle Code
DMV	Dept. of Motor Vehicles	PTO	Power Take Off	UNAPP	Unapplied
ELEC	Electric	PUC	Public Utilities Commission	USDOT	United States Department of Transportation
EMER	Emergency	QRV	Quick Release Valve	V	Vehicle
ERV	Emergency Relay Valve	REFL	Reflector	V-1	First Vehicle in Combination
EXH	Exhaust	REG	Registration	VEH	Vehicle
EXP	Expiration / Expired	REQ	Require or Required	X	Axle
EXT	Extinguisher	REQ'D	Required	X-1	First Axle
FB	Flatbed	RESV	Reservoir	XMBR	Cross Member
HAZ MAT	Hazardous Materials	R /	Right		

Example

5. Of the following choices, which one represents “vehicle one’s left brake on axle one is out of adjustment, out of service”

- (A) V-1 X1 BRK ADJ O/S
- (B) V-1 X1 L/BRK ADJ O/S
- (C) #1 AX-1 BRK LT O/S
- (D) V ONE L/SIDE BRK SYS ADJ

6. Based on the information contained in the box below, the choice which best represents the correct violation is:

COMMENTS: V-2 R/TL INOP V-3 REG EX

- (A) Vehicle two has expired registration and vehicle three has an inoperative right taillight.
- (B) Vehicle two has an inoperative right tail light and vehicle three has expired registration.
- (C) Vehicle two has an inoperative right turn signal and vehicle three has expired registration.
- (D) Vehicle two has an inoperative right turn lights and vehicle two has expired registration.

CONTINUED ON PAGE 5

SUBTEST 3: ANALYZING JOB RELATED SITUATIONS

Ability to analyze situations accurately and take effective action; ability to be firm and tactful in dealing with the public.

Subtest 3 measures (a) the analytical abilities a CVIS must possess to perform routine inspections of commercial vehicles (e.g., figure adjusted weight on scales, determine violations in log book) and (b) the basic abilities to be firm and tactful in dealing with the public.

Examples

7. A fifth wheel mounting plate is held on by 20 bolts to the frame. If more than 25 percent of the bolts are loose or missing, this is an out-of-service violation. How many bolts at a minimum would have to be loose or missing to be declared out of service?
- (A) 4 (this is 20%)
 - (B) 5 (this is actual 25%, not more than)
 - (C) 6 (25% of 20 = 5; this is the closest number more than 5)
 - (D) 7 (this is more than the minimum number necessary)

Use the information in the driver's log below to answer example question #8

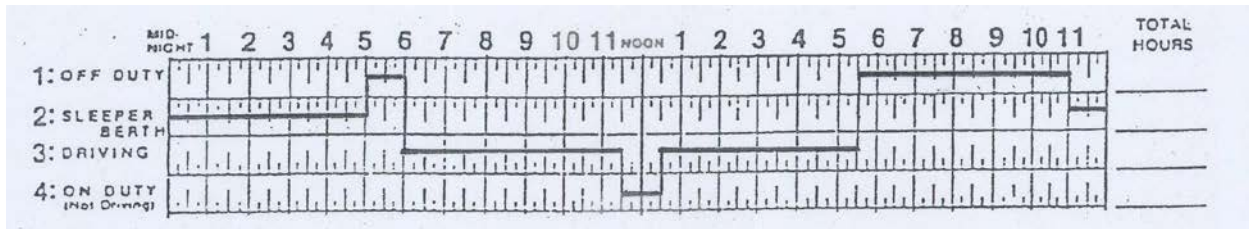

8. According to the driver's daily log book above, how many total hours did the driver spend in the sleeper berth?
- (A) 1 hour.
 - (B) 6 hours.
 - (C) 7 hours.
 - (D) 12 ½ hours.
9. The maximum gross vehicle weight of a vehicle combination by law is 80,000 pounds. The steering axle weight is 12,420 pounds, tractor tandem axles are 33,980 pounds, and trailer tandems carry the rest of the weight. How many pounds can the trailer tandems carry and remain in compliance?
- (A) 3,360 pounds (misplaced decimal place)
 - (B) 33,600 pounds (12,420 + 33,980 = 46,400; 80,000 - 46,400 = 33,600)
 - (C) 43,330 pounds (inaccurate subtraction)
 - (D) 46,400 pounds (did not subtract 46,400 from 80,000)

10. While working at the scale head, a driver is called into the office because the vehicle is overweight. The driver is upset and claims the scales are inaccurate because the vehicle was weighed at the yard before his/her trip.
- (A) Tell the driver he/she is wrong and get an Officer.
 - (B) Explain to the driver you understand his/her position, and explain that the scales are calibrated annually and proceed with the contact for the weight violation.
 - (C) Tell the driver the vehicle must be weighed at the next closest facility to your location.
 - (D) Apologize for the inconvenience and let the driver go after he/she shows you his/her company's weight ticket.
11. You receive a telephone call from a truck driver who states he/she was issued a citation (ticket) at another inspection facility for an equipment violation which he/she disagrees with. The driver asks if you will sign the citation without looking at the vehicle. The most appropriate response to the driver should be:
- (A) Sorry, we are closed.
 - (B) If you take the citation to another inspection facility, I am sure they will sign the ticket.
 - (C) If you promise you will fix the problem, I will sign the ticket without looking at the vehicle.
 - (D) In order to sign a citation that all mechanical repairs were completed, it is necessary to re-inspect the vehicle identified on the citation.

This ends the simplified question portion of the Study Guide

The list on page 7 provides examples of the terminology with which you should be familiar.

NOTE: Scratch paper will be provided at the test. Calculators are not permitted.

You should know the location and function of basic commercial vehicle systems and devices. The list below provides examples of the terminology with which you should be familiar.

BRAKE SYSTEM

- air lines
- brake chamber
- brake shoes
- check valve
- compressor
- dual master cylinder
- glad hand/hose coupler
- master cylinder
- push rod
- quick release valve
- relay emergency valve
- relay valve
- retarder
- slack adjuster
- tractor protection valve
- treadle valve
- trolley valve
- wet tank

SUSPENSION SYSTEM/FRAME

- air bag
- eye bolt
- shackle
- spring equalizer
- spring hanger
- torque arm
- U-bolts

FUEL SYSTEM

- crossover line
- filter

COUPLING DEVICES

- draw bar eye
- fifth wheel
- king pin
- pintle hook

STEERING SYSTEM

- ball joints
- drag link
- pitman arm
- steering ring knuckle
- tie rod

EXHAUST SYSTEM

- exhaust pipes/mufflers
- mounting brackets

TIRES/WHEELS/RIM

- lug nut
- spacers/studs/clamps
- valve stem and cap

LIGHTING DEVICES

- brake lights
- dimmer switch
- headlights
- reflectors
- side markers
- turn signals